

**HUSKY TRACTOR**

**MODEL 12  
HYDROSTATIC  
TRANSAXLE**

**service  
and  
maintenance  
instructions**

USED ON MODELS 197  
198  
1476

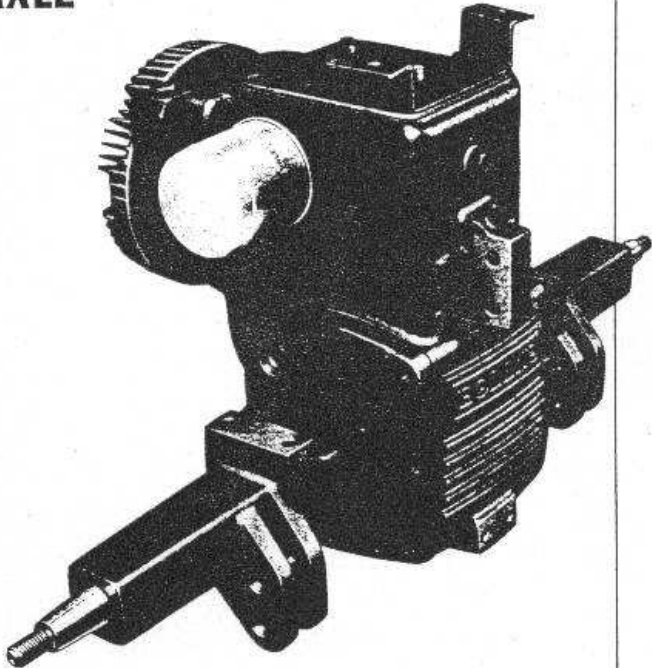

**fmc** **BOLENS**

PORT WASHINGTON, WISCONSIN, U.S.A.

FORM NO. 551841-2  
REVISED 4-69

## HUSKY HYDROSTATIC TRANSMISSION TABLE OF CONTENTS

	Page
Description .....	1
Marshallmatic Hydrostatic Flow Diagram .....	2
Operating of Vehicle .....	3
Function of the Tractor Transmission Lever .....	3
General Maintenance .....	4
Troubleshooting .....	4
Removal of Complete Transaxle Assembly from Tractor .....	5
Installation of Complete Transaxle .....	6
Travel-Pedal Dampener .....	6
Removal of Hydrostatic Package from Transaxle .....	7
Alternate Hydrostatic Package Removal Procedure .....	9
Installation of the Hydrostatic Package .....	9
Rear Axle Disassembly .....	11
Differential Disassembly .....	12
Differential Bevel Gear Backlash .....	12
Needle Bearing Replacement .....	12
Disassembly of Parking Pawl .....	13
Disassembly of Unloader Valve Button Assembly .....	13
Field Removal and Installation of Axle Seal .....	13
Parts List .....	13
Hydrostatic Exploded View .....	14

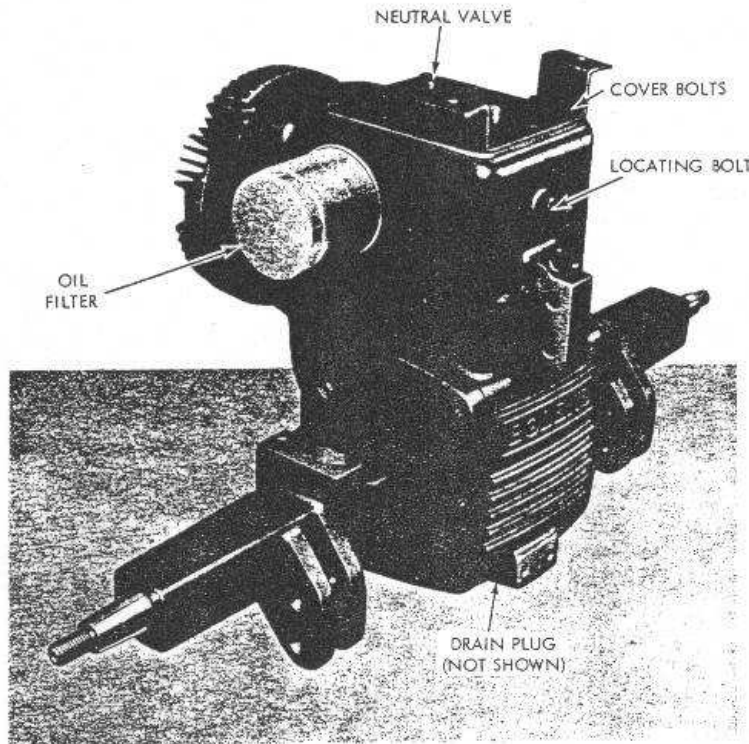

Figure 1

### DESCRIPTION

The Husky Model 12 hydrostatic transmission converts mechanical energy at the input shaft into pressure in a nearly incompressible working fluid, and then reconverts it into mechanical energy at the output shaft. The purpose of this transformation is to provide a means of varying the output torque, speed and direction, with a constant input speed. In operation the pressure within the hydrostatic transmission is variable and will increase and decrease

automatically as the drawbar load of the tractor increases and decreases.

The hydrostatic transmission is composed of three major parts - a variable displacement radial-piston pump; a fixed displacement gear motor; a system of valves located between the pump and motor. By varying the displacement of the pump, an infinite number of speeds are available within a range of 8 miles per hour in forward and 4 miles per hour in reverse at full engine R.P.M.

## MARSHALLMATIC HYDROSTATIC FLOW DIAGRAM

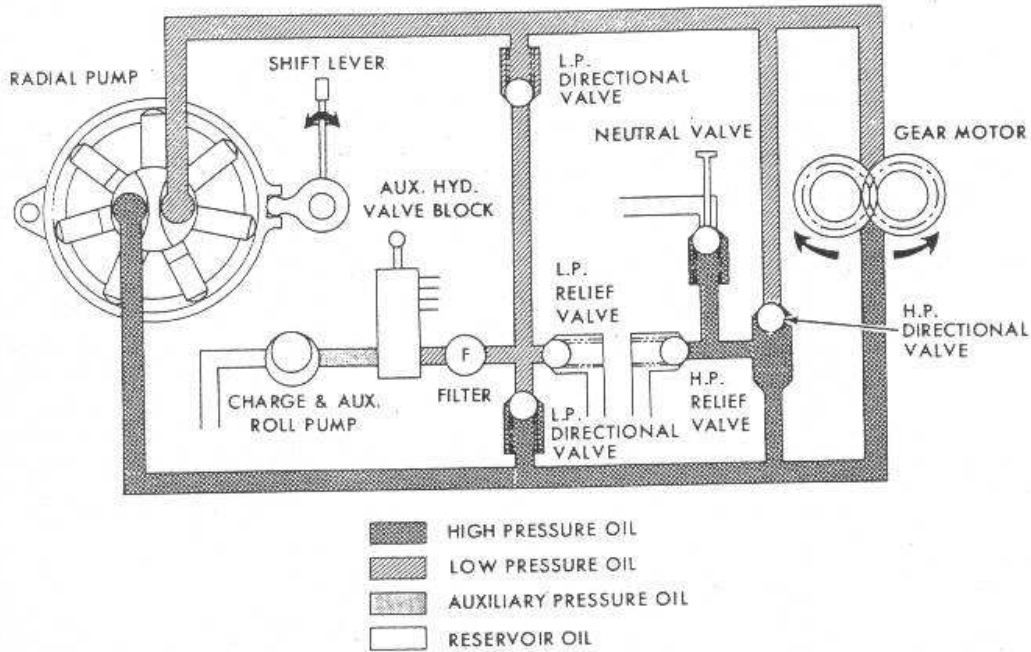

Figure 2

### FLOW DIAGRAM

In operation, the pump produces a flow of oil through internal channeling forming a closed loop between the pump and the motor. The oil flow produced by the pump is represented on the chart by the checked area and that flow returning from the motor to the pump is the crossed area.

Vehicle speed regulation is achieved by changing the oil delivery of the variable displacement pump. When the lever is moved in the forward (clockwise) direction, the cam ring is moved off center and oil immediately begins to flow through the circuit. Moving the position of the speed control pedal in the forward direction will vary the flow of oil, which in turn will vary the speed of the tractor. When the speed control pedal is moved in the reverse direction (counterclockwise), the flow of oil is reversed and the tractor will also reverse its direction. It should be kept in mind that since the circuit is a closed-loop and that oil is relatively incompressible, whatever flow reaches the fixed displacement motor will immediately be transmitted into a certain speed, depending on the volume and direction of the flow.

In order to better understand the circuit, refer to the white channeling on the flow diagram at the charge

or auxiliary roll-pump. This pump serves as the inlet for the hydrostatic transmission circuit and distributes the reservoir oil in the transaxle housing. The roll pump or charge pump performs three functions:

1. Maintains flow and pressure in auxiliary hydraulic circuit,
2. Maintains some pressure on the low-pressure side of the hydrostatic circuit so as to supercharge the variable displacement pump and,
3. Supplies oil lost due to internal leakage in the hydrostatic circuit.

Following the circuit from this point, the dotted channeling denotes the auxiliary pressure, established by a valve in the auxiliary hydraulic valve block. Next, the oil flows through a filter which removes particles of dirt and other foreign matter. The oil then flows to a pair of directional check valves and the low pressure relief valve. At this point there is more oil available than is needed to make up losses, so oil must circulate past the low pressure relief valve back into the reservoir. The directional valves are pressure dependent and the lower directional valve on the flow diagram is closed

due to the high pressure oil behind it, therefore, the make-up oil enters the upper or low-pressure side of the circuit. In reverse, the make-up oil enters through the lower directional valve.

All hydraulic circuits must be protected by a high pressure relief valve, which in this case is located in the circuit after the high pressure directional valve. Since a directional valve is used here, only one high pressure relief valve is required to protect the circuit whether it is operating in forward or reverse direction.

Finally, there is a neutral valve which is actuated by the tractor transmission lever. In order to achieve neutral or "free wheeling", the oil is "dumped" back into the reservoir, bypassing the gear motor. This makes it possible to move the tractor when in NEUTRAL while the engine is not operating. With the selector lever in PARK, the neutral valve is also open.

When the selector lever is in DRIVE, the neutral valve is allowed to close thus completing the "closed-loop".

### OPERATING OF VEHICLE

For optimum control and power, the Husky hydrostatic tractor should be operated at constant FULL-THROTTLE ENGINE SPEED. Complete control of the vehicle is accomplished through the use of the travel pedal. When operating the vehicle under varying load conditions, there will be a noticeable change in ground speed. It should be noted that when ground speed is reduced due to greatly increased loads, the speed control pedal should be directed toward the neutral position in order to increase the torque to the rear wheels. For example, if the engine starts to "lug" down while attempting to maintain a given speed when encountering a hill or other increased load, it is important to move the travel pedal toward neutral rather than toward full speed. This is the same as shifting down to a lower gear with a typical mechanical transmission.

Prolonged lugging or full travel-pedal position that demands maximum engine output will raise engine

and hydrostatic oil temperatures. If the vehicle has been performing under the previously mentioned condition, allow it to operate at a lower ground speed (lighter load but at FULL ENGINE R.P.M.), then normal operating temperatures will again be established. 160°-170°F. is the normal operating temperature of the hydrostatic. These temperatures will feel hot "to the touch".

### IMPORTANT

OPERATOR MUST KEEP FOOT ON THE TRAVEL-PEDAL FOR MAXIMUM CONTROL OF TRACTOR. MOVING TRAVEL-PEDAL MANUALLY TO NEUTRAL OR BEYOND TO OBTAIN DESIRED DECELERATION BY MEANS OF DYNAMIC BRAKING IS THE METHOD INTENDED IN HYDROSTATIC DESIGN.

### FUNCTION OF THE BOLENS TRACTOR TRANSMISSION LEVER PARK - NEUTRAL - DRIVE

The Husky Model 12 hydrostatic transmission has a closed hydraulic circuit, therefore, the vehicle cannot be pushed unless an oil by-pass exists. This oil by-pass operates in conjunction with the transmission lever as described above.

1. When the transmission lever is in the DRIVE or closed position, the vehicle is operated entirely with the speed control pedal. When the transmission lever is in the NEUTRAL or center position, the vehicle may be pushed by hand; whether or not the engine is running.

2. When in the PARK or rear position, the vehicle should not be pushed under any circumstances because of possible damage to the parking lock.

### NOTE

The transmission lever should never be placed in the PARK position when the vehicle is moving.

### CAUTION

Do not tow or free wheel over 8 MPH.

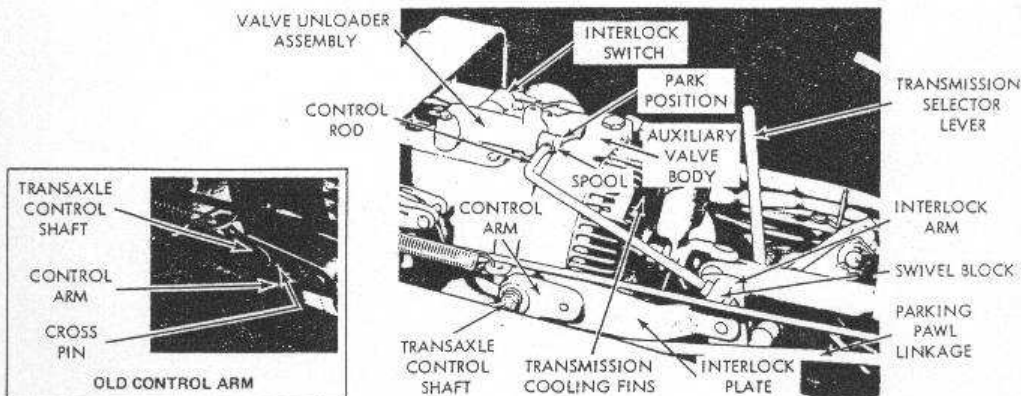

Figure 3

## GENERAL MAINTENANCE

### OIL LEVEL

The oil level should be checked after every eight hours of operation and should always be maintained between the add and full lines on the dipstick. Allow the engine to idle for a few minutes before checking the oil level. If it is necessary to add oil, only type A transmission fluid or special oil available from Bolens should be used.

### IMPORTANT

ALWAYS WATCH FOR OIL LEAKS AT HOSES, SEALS AND FITTINGS. LOW LEVEL OR INADEQUATE OIL WILL RESULT IN PERMANENT DAMAGE TO HYDRAULIC SYSTEM.

### OIL FILTER (Fig. 1)

The Husky Model 12 transaxle is equipped with a replaceable oil filter which can be removed by turning it counterclockwise. Oil filter change:

Home Owners: Once a year or 300 hours.  
Industrial or Commercial: Once every three months or whenever dipstick check indicates dirty oil.

### COOLING

To maintain proper cooling, the transaxle exterior should be kept free of dirt, oil and grass, particularly the finned area behind the fan.

### NOTE

Numbers in parentheses ( ) in text correspond to numbers shown on exploded parts view, page 14.

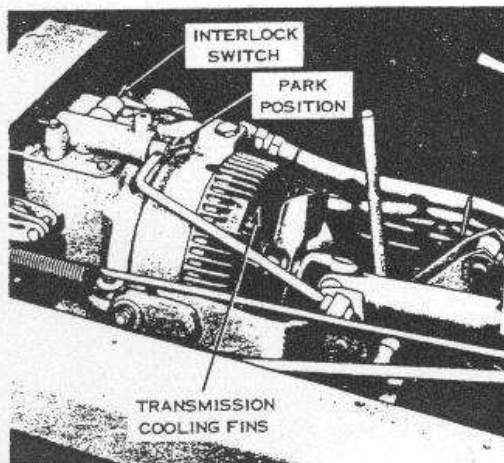

Figure 4

4

## TROUBLESHOOTING

### TRACTOR PERFORMANCE CHECK OF ENGINE & TRANSMISSION

To perform a temporary power check, carefully "square off" or align both front wheels evenly against a solid wall. With both front tires firmly against this wall, pull throttle control knob out 3/4 to full, and gradually depress speed control pedal applying load slowly until tires spin.

### NOTE

Tires normally will spin on dry concrete or macadam with the standard 27-8:50 x 15 tires with no additional rear-end loading except the operator. Terra tires, 26-12 x 12, will be more difficult to spin, especially on rough dry concrete.

### IMPORTANT

THIS IS ONLY A TEMPORARY PROCEDURE TO AID IN QUICKLY CHECKING OUT GENERAL ENGINE AND TRANSAXLE PERFORMANCE. HOWEVER, A FEW TRIES ARE USUALLY ADEQUATE TO ALLOW AN EXPERIENCED MECHANIC TO OBSERVE GENERAL ENGINE PERFORMANCE, SUCH AS ENGINE MISS, CARBURETOR ADJUSTMENTS, GOVERNOR ACTION, ETC.

If engine performance appears to be normal and a thorough inspection of loose linkage connections, leaks, adjustments, etc., has been carried out, then proceed as follows.

1. On 1250 tractors only, remove spring from speed hold pedal.
2. Remove complete fender assembly (two capscrews, one on either side, holding front fender to frame and two bolts under the seat). Disconnect tail light wire.

### CAUTION

TRANSMISSION DRIVE-LINE FAN NOW EXPOSED. IF AN ATTEMPT IS MADE TO TEMPORARILY RUN THE ENGINE, BE AWARE OF SPINNING FAN BLADES WHILE ENGINE IS RUNNING.

3. Observe all mechanical linkage; free up, tighten or correct if necessary.
4. Recheck all hydraulic connections and seals for leakage.

### LOSS OF POWER:

- A. Drive-Neutral-Park control rod not adjusted properly to unloader actuator (located on top of transmission cover).
- B. Oil level in transmission below level.
- C. Defective O-ring (11).
- D. Defective hydrostatic package (16).

- E. Foot brake adjustment too tight.
- F. Unloader valve sticking (should return freely) (8).
- G. Defective unloader actuator.

**LOSS OF OIL:**

Defective or damaged parts:

- A. O-Ring (17)
- B. Cover Gasket (3)
- C. Unloader Valve Button Gasket (7)
- D. Parking Pawl Gasket or O-Rings (21, 22, 23)
- E. O-Ring (18)
- F. Axle Oil Seal (33)
- G. Gasket (27)
- H. Service Brake Shaft Seal (54) or Gasket (60)

**NOTE**

To replace O-Rings (17 and 18), follow instructions on page 9.

- I. Defective Lift Valve
  - J. Leaking Lift Cylinder
  - K. Defective or loose hydraulic lift hoses and fittings
- LIFT VALVE AND CYLINDER WILL NOT LIFT OR HOLD**
- A. Defective or leaking lift valve.
  - B. Leaking cylinder.
  - C. Hydraulic lift hoses crossed at transmission outlet ports.
  - D. Defective hydraulic hoses. Plugged or kinked.
  - E. Defective charge pump in Hydrostatic.

**TRAVEL PEDAL FLUTTER**

After usage the speed control pedal may develop a pronounced flutter. This could occur with engine at fast idle: -transmission lever in DRIVE; -and foot removed from speed control pedal. The DAMPENER adjustment described on Page 6, Fig. 5 will again produce desired action.

**REMOVAL OF COMPLETE TRANSAXLE ASSEMBLY FROM TRACTOR**

Cleanliness is the first order. Clean the transmission prior to disassembly.

1. On 1250 tractors only, remove return spring from speed hold pedal.
2. Remove complete fender assembly (two capscrews, one on either side, holding front fender to frame and two bolts under the seat). Disconnect tail-light wire.

3. Drain oil - the oil plug (15) is located at the bottom of the transmission. After transaxle is drained, reinstall plug.
4. Remove brake rod return spring from seat bracket.
5. Remove seat bracket, two bolts per side.
6. Remove oil filter from transaxle (9).
7. Remove hydraulic lift lines and tie loose ends up to steering wheel.

**NOTE**

Temporarily mark either top or bottom hydraulic lift hoses (so they are not accidentally crossed at reassembly). Lift ram will not operate if hoses are crossed.

8. Remove the upper and lower hydraulic elbow fittings from the hydrostatic package.
9. Remove hydraulic unloader valve actuator assembly located on top side of transaxle cover by removing two capscrews holding casting over unloader valve cap. Pivot the unloader valve actuator and rod assembly and lean forward against steering column.
10. Remove two bolts (right side) to remove complete brake assembly and disc.
11. Remove cotter pin and clevis pin from control arm interlock plate; remove cotter key from parking pawl linkage at transmission end - allow loose end to swing down.
12. Slightly raise and safely block up tractor main frame just forward of transaxle so tires barely leave floor.
13. Remove the four capscrews (two per side) that hold transaxle to main frame.

**CAUTION**

CAREFULLY BALANCE TRANSAXLE WHILE REMOVING MAIN FRAME CAPSCREWS, TO AVOID ACCIDENTAL INJURY OR TRANSAXLE DAMAGE. ROLL TRANSAXLE OUT OF TRACTOR FRAME. WHEN REMOVING THE TRANSAXLE FROM THE FRAME, THE DRIVE-LINE WILL SLIP OFF THE TRANSMISSION INPUT SHAFT.

**NOTE**

Do not allow drive-shaft to drop free. Fan blade damage could result.

14. Remove woodruff key from transmission input shaft; wheels, hubs and drive keys from axles.
15. Remove hex nut, lockwasher and washer holding control-arm to control shaft, Figure 3. With a small gear puller remove control arm from shaft. Remove control arm interlock plate.

**NOTE**

If hydrostatic is the older model, the control-arm is held on with a drive cross pin. (See insert Figure 3.)

Use a 3/16" drift punch to drive out pin. Locate punch on pin through slot of the control-arm and drive out pin toward rear of transaxle assembly.

## INSTALLATION OF COMPLETE TRANSAXLE

### IMPORTANT

"CLEANLINESS IS THE FIRST ORDER!" ALWAYS AVOID DUST, GRIT OR OTHER CONTAMINATION WHEN WORKING WITH HYDRAULIC CONNECTIONS.

### INSTALLATION

1. Install hubs, keys and wheels on replacement transaxle.
2. Install woodruff key into keyway of transmission input shaft.
3. Temporarily remove new oil filter from replacement transaxle to avoid damage.
4. Reinstall linkage on transaxle control shaft.
5. Install replacement transaxle. Grease input shaft, and carefully guide input shaft into drive line. Bolt replacement transaxle to tractor main-frame with the four capscrews. (TIGHTEN TO 60 FOOT POUNDS.)
6. Install drive keys to axles - install hubs and wheels.

### NOTE

Liberally apply grease to rubber O-ring on filter.

7. Reinstall the new filter by grasping with both hands and tighten securely.
8. Reinstall parking pawl linkage by inserting link into pawl cross hole and insert cotter pin (Fig. 3).
9. Grease spline and reinstall disc brake assembly.
10. Reinstall elbows into auxiliary valve body as shown on Figure 3.
11. Reinstall hydraulic-lift hoses.

### NOTE

Upper and lower hoses must be reinstalled in their original position.

12. Install seat bracket.
13. Reassemble foot brake and return spring to brake rod loop provided; anchor other end of spring to hole provided in seat bracket.

### LINKAGE ADJUSTMENT (Refer to Fig. 3.)

1. Reinstall hydraulic unloader-valve assembly with two bolts onto transaxle cover.
2. Turn the two jam-nuts on control rod away from swivel block. Place transmission lever in PARK position so parking pawl is fully meshed in bull-gear.

3. Push spool of the neutral valve unloader assembly back into the PARK detent position (front detent groove inside casting under the spring loaded ball).

4. Securely tighten jam-nuts against swivel block.
5. Cross-check jam-nut adjustment by placing Selector Lever in NEUTRAL position.

6. Push tractor forward and back to determine if tractor free-wheels. Then place transmission lever into DRIVE. Activate foot pedal, and observe if slot pin in transaxle control linkage moves freely into upper and lower slot of interlock plate. If interference is evident, readjust jam-nuts slightly to eliminate "interlock vs. slot-pin" interference.

## TRAVEL-PEDAL DAMPENER (REFER TO FIGURE 5)

The Model 12 Bolens Husky is equipped with a Travel-Pedal Dampener which consists of the travel-pedal control-rod pivot block #171-9041, Reference A, and two bowed washers #171-9453, Reference B, mounted on the hydrostatic control linkage located on the right-hand side of transaxle. Note the position of the two special bowed washers as viewed from the rear. If washers are not positioned in the manner shown at Reference B in the drawing, correct before attempting adjustments outlined below.

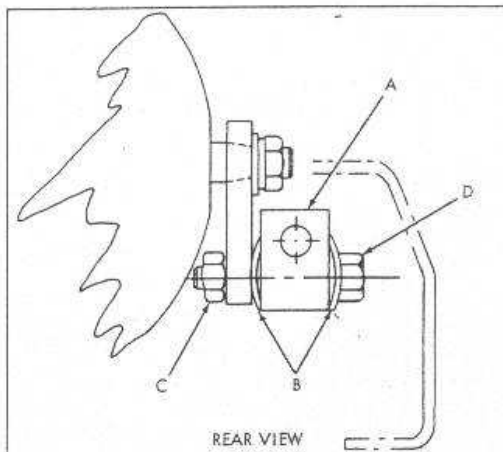

Figure 5

When the Travel-Pedal Dampener is adjusted too tight, the travel-pedal will return toward neutral very slowly or not at all, thus a creeping action will result. If pedal action appears too stiff, locknut C and capscrew D should be loosened to readjust pedal dampener to obtain just a slight resistance when moving travel-pedal by hand. Relock capscrew D with locknut C while holding capscrew D in that position.

If pedal action is too loose, which may occur after some vehicle usage, a pedal flutter may become apparent. To adjust, loosen locknut C and tighten capscrew D one flat at a time (1/6 of a turn) until flutter is eliminated; then relock capscrew D with locknut C while holding capscrew D in that position.



## FENDER INSTALLATION

1. Place selector lever in NEUTRAL (Fig. 4).
2. Reinstall seat and fender assembly. Tighten all four fender bolts securely.
3. Reconnect tail-light wire.
4. Refill transaxle with approximately 8 quarts of Texamatic No. 1846-6159, Bolens Part No. 171-9650.

### NOTE

Oil level check can be disregarded at this point.

5. With selector lever in PARK, run engine at half to three quarter throttle, purge air from hydraulic lift cylinder, by cycling lift cylinder until ram action is smooth.
6. Recheck all hydraulic connections and oil filter for leaks.
7. Idle engine, then add additional hydraulic oil up to plug level (usually 1-1/2 to 2 quarts required).

### NOTE

Oil level can not be accurately checked if the tractor has been sitting for any length of time. (Oil may run out if dipstick is removed when engine is not running.)

8. Place selector lever in PARK position; run engine for at least two minutes. This procedure will again allow the oil to re-fill all internal hydraulic circuits.

9. With engine idling remove dipstick to observe if oil level is up to bottom of threads of filler plug hole.

### IMPORTANT

BEFORE CHECKING OIL ALWAYS THOROUGHLY CLEAN AREA AROUND DIPSTICK PLUG TO AVOID DIRT OR OTHER CONTAMINATION FROM ENTERING TRANSAXLE.

10. Normal operating temperature of oil is approximately 100° F above ambient temperature. An oil level check when transmission is hot will read overflow. Always idle unit for a short period to allow transaxle to cool down to obtain the best oil level reading.

## REMOVAL OF HYDROSTATIC PACKAGE FROM TRANSAXLE

### NOTE

Removal of the hydrostatic package (16) from the transaxle can be accomplished without removing the complete transaxle from the frame of the tractor. Hydrostatic package will be handled as a factory exchange only. Piece parts other than those listed on pages 13 and 15 are not available as separate repair parts because of select fits required.

1. Follow procedures on page 5 using steps 1 thru 11 only.

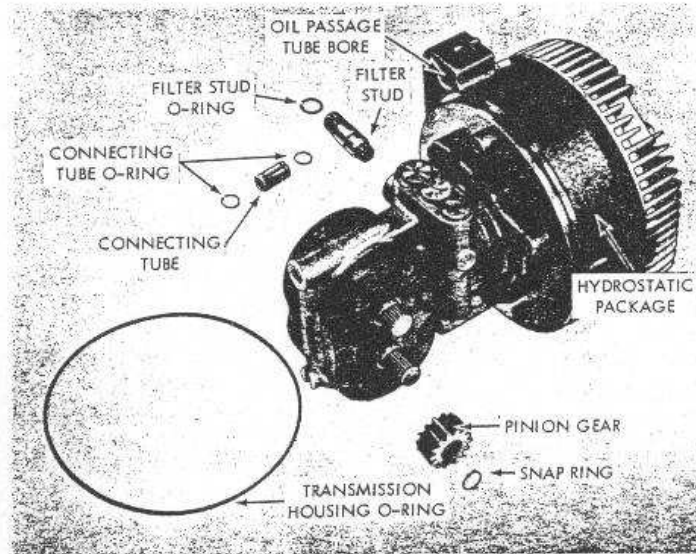

Figure 6

2. Loosen set screw, remove drive-line positioner (bolt with stop nut) from front joint at engine; move drive-line toward front so the rear joint clears the end of transmission shaft. Then completely remove drive-line assembly by pulling complete drive-line down and off the engine crankshaft. **AVOID BENDING FAN BLADES ON DRIVE-LINE.**

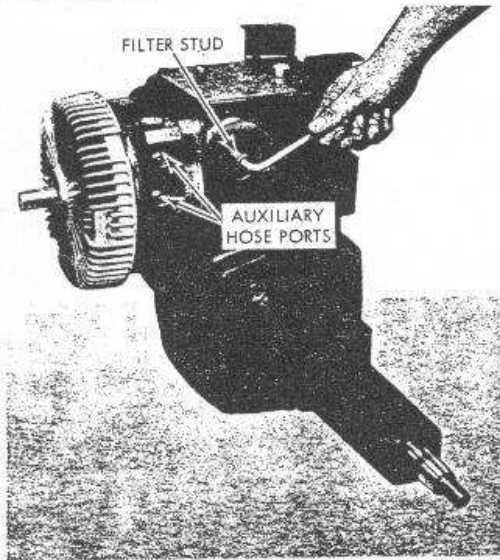

Figure 7

3. Refer to Figures 7 and 17, and remove filter stud using a wide blade screwdriver - on new design stud, use 3/8" Allen wrench to remove stud.

**NOTE**

O-Ring should be loose on filter stud.

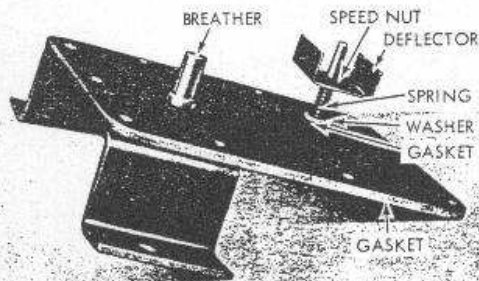

Figure 8

4. Remove cover bolts (1, 1A, 59), lift off cover bracket (earlier style bracket welded to cover), remove cover sub-assembly and cover gasket (2 and 3) (Fig. 8 and 17).

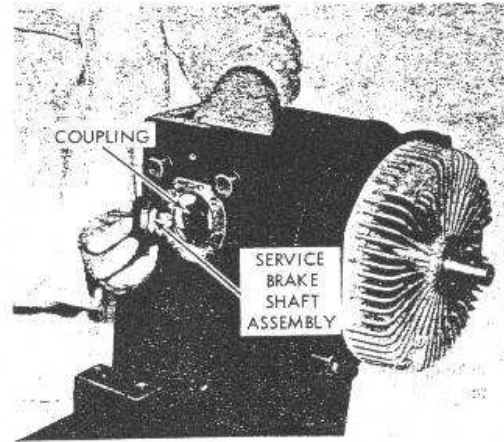

Figure 9

5. Remove brake flange, four bolts and gasket (59 and 61), tap lightly and pull out brake flange assembly (55). Observe to see that brake coupling (52) is also removed (Fig. 9 and 17).

6. Remove locating bolt (12) and gasket (13) (Fig. 1 and 17).

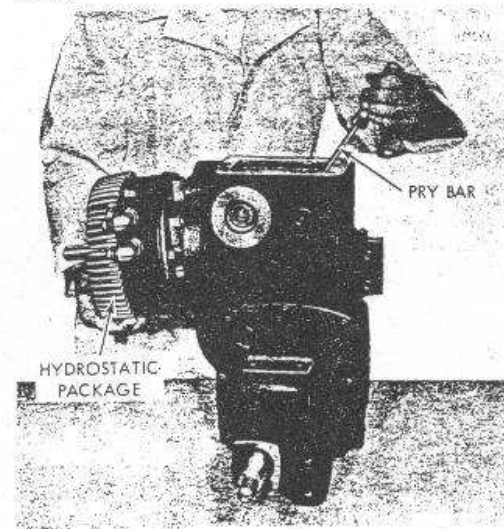

Figure 10

7. Firmly hold input-shaft (or lower fin area) of hydrostatic transmission with right hand - use screwdriver and wedge lightly between inside of transmission housing and rear surface of hydraulic motor block casting - lightly pry transmission forward. Then use both hands to move hydrostatic package out of transaxle housing, using a rocking motion (Fig. 10).

## ALTERNATE HYDROSTATIC PACKAGE REMOVAL PROCEDURE

Removal of hydrostatic package from transaxle (16) - Page 8.

If universal joint set-screw at engine end of drive line cannot be loosened, the following step can be taken to remove transmission. (Follow all steps except step 2.)

### IMPORTANT

REPLACE STEP 2 WITH THE FOLLOWING INSTRUCTIONS.

Remove three of the four capscrews holding transaxle to main-frame of tractor.

### CAUTION

Support the transaxle by holding the cover bracket (transaxle is front-end-heavy and will tip forward if not held manually in original plane) while removing fourth capscrew.

Carefully push main-frame forward very slowly while holding transaxle stationary (wheels still on transaxle) until rear hole of frame is indexed with front hole of transaxle. Again insert one capscrew and tighten.

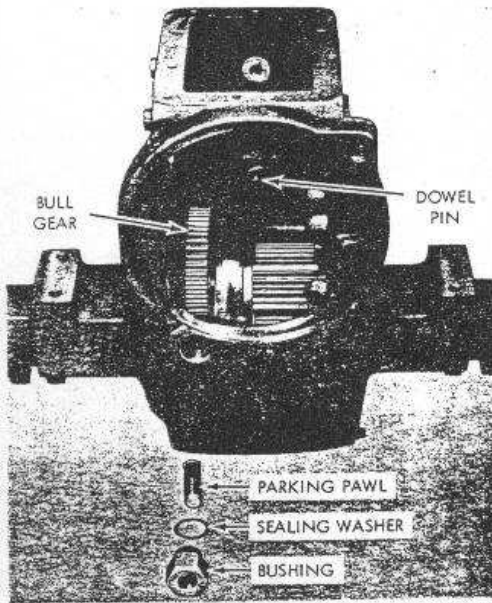

Figure 11

With standard tires - remove 3 bolts and loosen the right rear to allow unit to be pivoted to the left. With large tires, bolt as spelled out above.

### NOTE

The drive line will slide off the transaxle input shaft. Then the hydrostatic package can be removed from the transaxle housing.

For installation, reverse above procedure.

## INSTALLATION OF THE HYDROSTATIC PACKAGE

Whenever replacing hydrostatic package (16), use Gasket Kit (62).

1. Reinstall linkages on transaxle control shaft.
2. Before installing hydrostatic package, inspect O-ring (17) for cuts, nicks and etc. Carefully install O-ring (17) in groove in hydrostatic housing. Be sure O-ring is not twisted. If O-ring is twisted insert small, smooth, blunt rod between O-ring and groove and run around housing slowly. This will allow O-ring to untwist. Liberally coat O-ring with heavy oil or grease to prevent damage in installation.
3. Check oil passage tube (19) and O-rings (18) (must be free of cuts, nicks and etc). Install O-ring in grooves in oil passage tube (19) again checking to be sure O-rings are not twisted. Coat O-rings with heavy oil or grease to prevent damage in installation. Insert tube into hydrostatic bore shown in Figure 6.
4. Carefully insert hydrostatic package partially into main housing (51).

### NOTE

A slot located on the back end of the motor of the hydrostatic package should be centered on the dowel pin (Fig. 11) of the main housing. This mating can be observed through the top cover access-hole.

5. With the slot in line with the dowel pin, carefully insert the package (16) observing the O-ring (17).

### IMPORTANT

THIS RING SHOULD NOT BE PINCHED OR CUT AT ASSEMBLY. DURING THE ASSEMBLY, CAUTION SHOULD ALSO BE TAKEN IN ENTERING THE OIL TUBE (19) WITH MATING BORE IN MAIN HOUSING (51). COMPLETE INSERTION OF THE HYDROSTATIC PACKAGE INTO THE MAIN HOUSING CAN BE ATTAINED BY PLACING A FLAT TOOL BETWEEN THE RECESS LOCATED IN FRONT OF THE THREE ACCESS CAPS ON THE MOTOR BLOCK AND THE FRONT TOP COVER FLANGE AND WEDGING INTO PLACE.

6. Before inserting special positioner bolt with gasket (12 and 13), observe to see if the dowel pin (Fig. 11) in the transaxle housing is in line with hydrostatic motor casting slot. If not, gently move (using rocking motion) in place. Insert bolt (12) and start thread engagement by hand.

#### NOTE

The pinion gear hydrostatic motor-shaft will mesh automatically with bull gear (Fig. 11) when special 1/2" positioner bolt (12) is securely tightened. Torque to 40 ft. lbs.

7. Reinstall filter stud (10) and filter (9).

8. Insert spline coupling (52) onto splined shaft of brake flange assembly (55) with gasket (60), insert this assembly on spline shaft of the motor. Tighten securely with four bolts and gaskets (59 and 61).

9. Reinstall parking pawl linkage by inserting link and cotter pin.

10. Reinstall disc brake assembly.

11. Reinstall elbows into auxiliary valve body located on left front side of transaxle.

12. Reinstall hydraulic-lift hoses. Upper and lower hoses must be reinstalled in their original position.

#### NOTE

Upper hose goes to left hand side of valve and lower hose goes to right hand side of valve.

13. Reinstall keys and drive-line after lubricating both shafts.

14. Insert special positioner bolt through front joint and engine crankshaft, tighten securely.

15. Reinstall hitch and rear seat bracket.

16. Reassemble foot-brake and return spring to brake rod ear provided; other end of spring to hole provided in seat bracket.

#### TRAVEL PEDAL LINKAGE ADJUSTMENT (Refer to Fig. 3)

With the selector lever in its DRIVE position, all transmission linkage should move freely.

1. Reinstall hydraulic unloader valve assembly with two bolts onto transaxle cover.

2. Turn the two jam-nuts on control rod away from swivel block, then place selector lever in PARK position.

3. Push spool of unloader assembly back into the PARK detent position. (Front detent groove inside casting.)

4. Adjust the two jam-nuts on swivel block of selector arm at that position. Cross-check jam-nut adjustment by placing selector lever in NEUTRAL position. Then push tractor forward and back to determine if tractor free-wheels freely.

5. Place lever into DRIVE. Then by activating foot pedal, observe if pin in transaxle control linkage moves freely into upper and lower slot of interlock plate. If interference is evident, readjust jam-nuts to eliminate "interlock vs. slot-pin" interference.

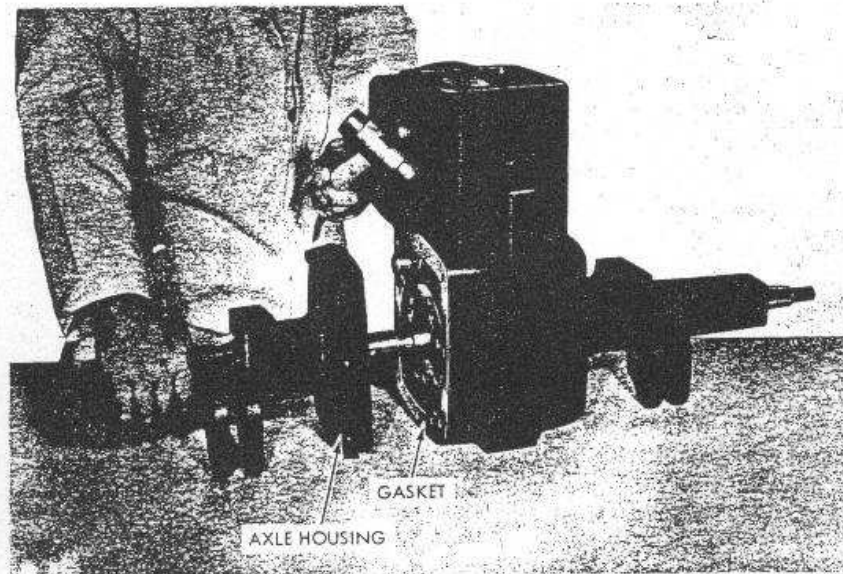

Figure 12

6. Place selector lever in NEUTRAL; reinstall seat and fender assembly. Tighten all four bolts securely.

7. Reconnect tail-light wire.

8. Refill transaxle with approximately eight quarts of Texamatic No. 1846-6159, Bolens Part No. 171-9650. Oil level check can be disregarded at this point.

9. Run engine at half to three quarter throttle, purge air from hydraulic lift cylinder, by cycling lift cylinder until ram action is smooth.

10. Check all hydraulic connections and filter for leaks.

11. Idle engine, then add additional hydraulic oil up to plug level. (Usually 1-1/2 to 2 quarts required.)

**NOTE**

Oil level. See page 7.

**REAR AXLE DISASSEMBLY**

1. Remove eight axle housing bolts (25) securing axle housing to transaxle housing.

2. Tap axle housing lightly with plastic or rawhide mallet to loosen the seal. Slide axle housing off axle carefully to prevent damage to oil seals (Fig. 12).

3. Remove gasket (27) and clean casting surfaces (Figs. 12 and 17).

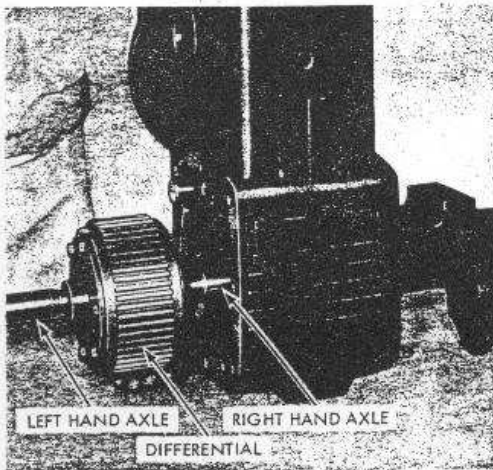

Figure 13

4. Carefully slide differential assembly from transaxle housing to prevent damage to oil seals (Fig. 13).

**NOTE**

It is not necessary to remove hydrostatic package from the transaxle housing to accomplish differential removal.

5. In order to accomplish removal of remaining gears, it is necessary to remove the hydrostatic package.

6. Refer to Figures 14, 15 and 17, and remove bowed E-ring (47). While holding bull gear (48), slide intermediate shaft (50) and spacer (49) out of transaxle housing.

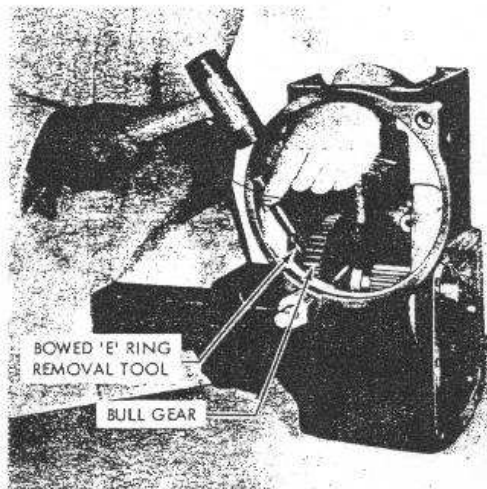

Figure 14

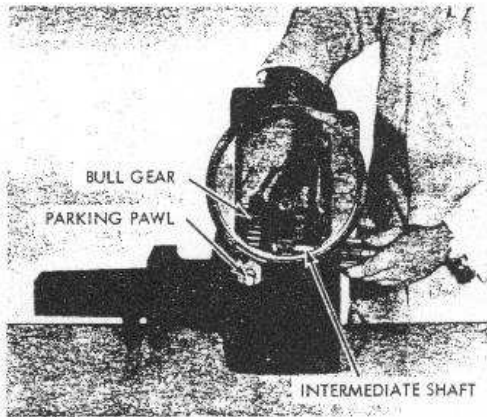

Figure 15

## DIFFERENTIAL DISASSEMBLY

7. Remove six bolts (34) from the differential assembly. Tap either axle shaft lightly until either axle assembly (right or left) is separated from the ring gear (37) and remove remaining axle assembly (Fig. 16 and 17).

8. Remove floating pinion shaft, pinion gear and thrust washer (43, 41, 40) from ring gear (37) (Fig. 16 and 17).

9. Remove retaining ring (42) from axles, separate side gear, shim and cover (39, 38, 36 or 44) (Fig. 16 and 17).

### NOTE

Right axle (45) has cover (44). Left axle (35) has cover (36).

### NOTE

During reassembly, it should be noted that the overall length of the right hand axle is greater than the left hand axle by more than two inches. Head of the through bolts should always face the left hand axle.

## DIFFERENTIAL BEVEL GEAR BACKLASH

When checking backlash, support differential on either end cover face only. Insert feeler gauge between shim and end-cover face through either one of the three end-cover slots. Add shims, if necessary, to obtain proper backlash of .001 to .007.

## NEEDLE BEARING REPLACEMENT

If bearings need replacing, press new bearings beyond machined casting surface as follows:

Axle bearings right and left (32) .040 below machined face.

Needle bearing (28) .00-.03 below machined face.  
Needle bearing (46) .005/.020 below machined face.

Any part showing abnormal wear should be replaced.

Reverse procedure of disassembly in assembling the transaxle.

### NOTE

When reassembling the transaxle and hydrostatic package, use gasket kit (63).

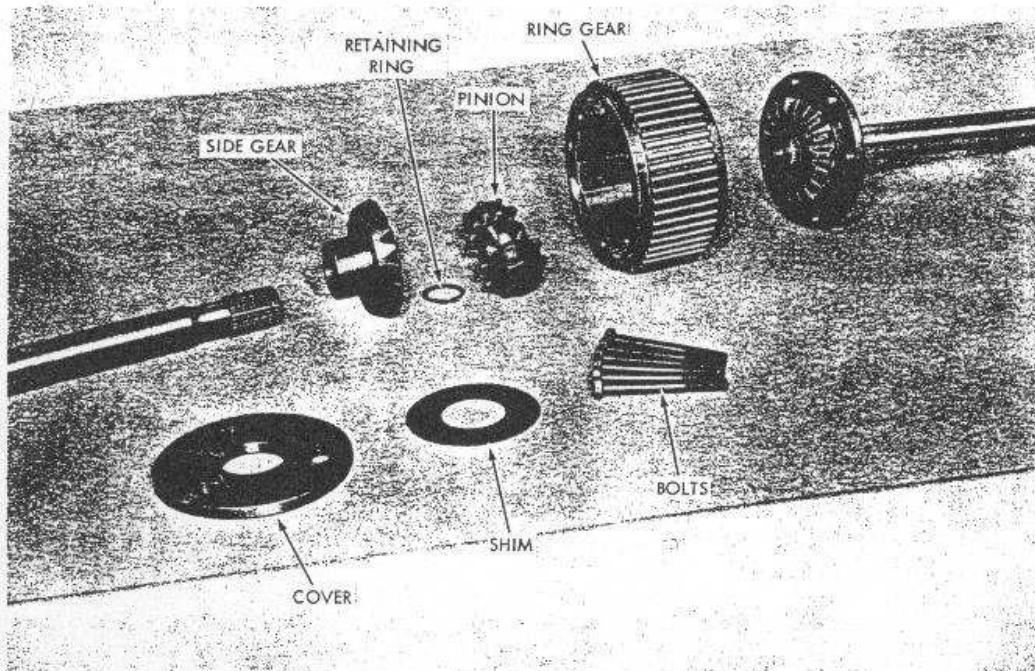

Figure 16

## DISASSEMBLY OF PARKING PAWL

Unscrew parking pawl assembly bushing (20), remove gasket (21) and parking pawl (24). Replace O-rings (23 and 22) and gasket (21), if necessary. When re-assembling grease O-rings and gaskets, torque hex bushing (20) to 40 ft. lbs. (Fig. 15 and 17).

## DISASSEMBLY OF UNLOADER VALVE BUTTON ASSEMBLY

1. Follow step 4 of hydrostatic package removal.
2. Remove tinnerman speed nut (4), deflector (4A), spring (5), washer (6) and button assembly gasket (7) (Fig. 8 and 17).

When reinstalling, clean all parts thoroughly and replace button assembly gasket and speed nut. Before placing covers on transaxle, be sure the deflector is positioned as pictured in Figure 8, folded sides to straddle the valve caps on hydraulic motor block.

## FIELD REMOVAL AND INSTALLATION OF AXLE SEAL

### REMOVAL

1. Drain oil (approximately eight quarts) into clean container.
2. Reinstall drain plug after oil has been drained.
3. Block up tractor.
4. Remove wheel, hub, and key.
5. Clean area around axle and seal.

6. Remove paint, burrs and sharp edges.
7. Remove axle seal with hook type tool.
8. Clean and dry seal bore and axle. Observe condition of axle in seal lip area and check machined seal-recess for irregularities.

### INSTALLATION

1. Coat inside of seal lip with lubricant.
2. Coat outside diameter of seal with oil resistant sealer.
3. Carefully slip seal over axle shaft towards the axle housing seal-bore.
4. Set seal into position applying smooth uniform pressure.

### IMPORTANT

DO NOT COCK OR DISTORT SEAL. CARELESSNESS COULD RESULT IN OIL LEAKAGE.

5. Reinstall key, hub, and wheel.
6. Remove dipstick (14) and refill with Boiens #171-9650 Texamatic or automatic transmission ATF type 'A'.
7. Reinstall dipstick.
8. Start engine and run for at least two minutes.
9. Recheck oil level while engine is idling.
10. Recheck the entire hydraulic system for leaks.

### PARTS LIST FOR HUSKY TRANSAXLE ASSEMBLY

REF. NO.	BOLENS PART NO.	EATON PART NO.	DESCRIPTION	NO. REQ'D
1	1106832	ET-94428-5/8	Capscrew 1/4-20 UNC x 5/8	3
1A	1720287	ET-94428-3/4	Capscrew 1/4-20 UNC x 3/4	2
2	1719851	ETS-22630	Cover Service Kit (Includes 1A, #3 and #4)	1
3	1719852	ET-8484	Gasket (Transmission Cover)	1
4	1719853	ET-94423	Speed Nut	1
4A	1719854	ET-93782	Deflector	1
5	1719855	ET-94422	Spring	1
6	1719856	ET-94427	Washer	1
7	1719857	ET-8465	Gasket (Button Assembly)	1
8	1719858	ET-22565	Unloader Button Sub-Assembly	1
9	1719859	ET-94860	Oil Filter	1
10	1719860	ET-94853	Filter Stud	1
11	1720309	ER-8277	"O" Ring (Filter Stud)	1
12	1719861	ET-94855-2-1/2	Capscrew 1/2-13 UNC x 2-1/2	1
13	1719862	ET-94426	Seal Washer (Mounting Bolt)	1

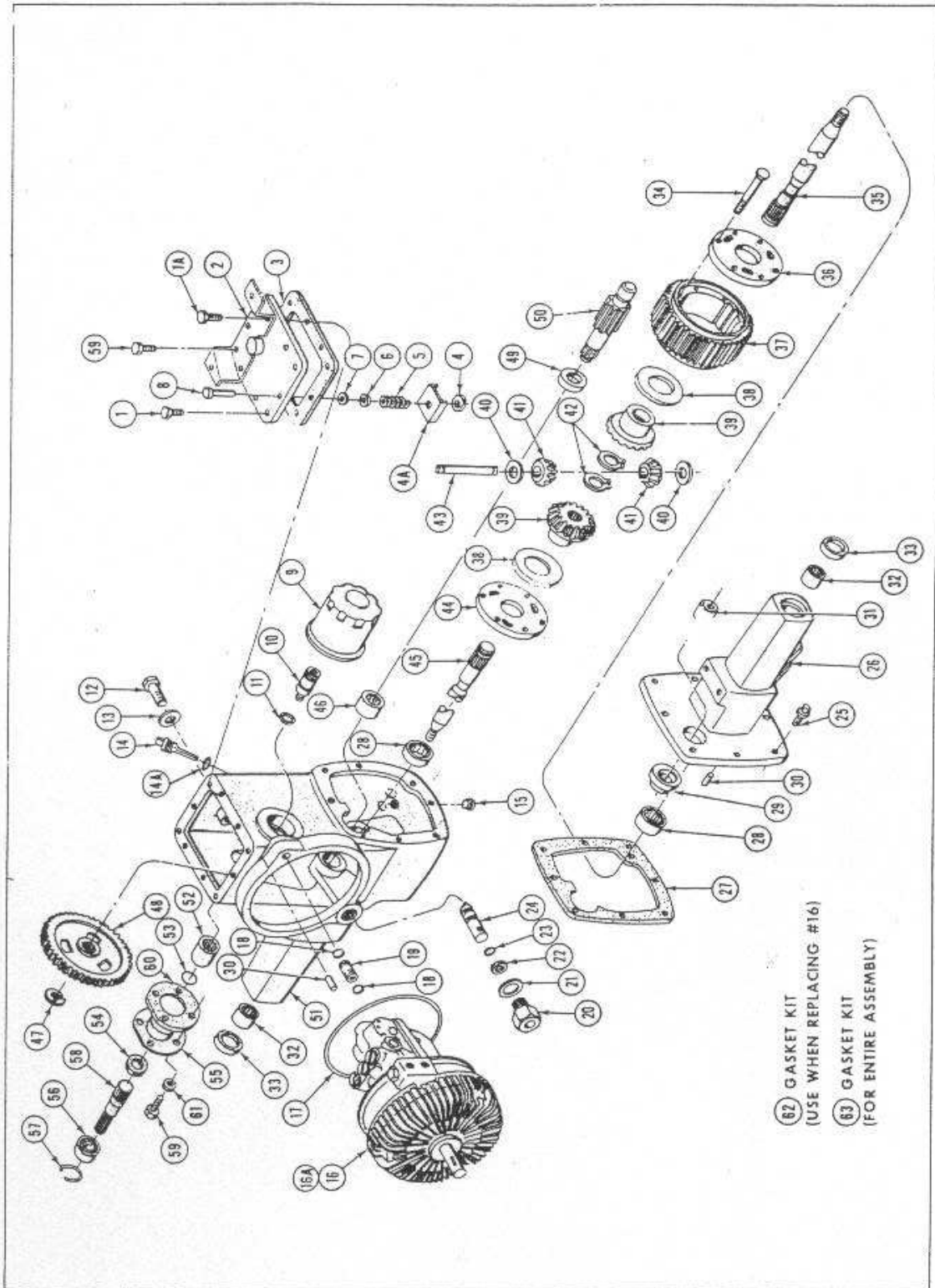

Figure 17



**PARTS LIST FOR  
HUSKY TRANSAXLE ASSEMBLY**

REF. NO.	BOLENS PART NO.	EATON PART NO.	DESCRIPTION	NO. REQ'D
14	1719863	ET-94893	Dipstick	1
14A	1720310	ER-8284	"O" Ring (Dipstick)	1
15	1720311	ER-91604	Drain Plug 1/4-18 NPTF	1
16	1719864	ET-12764-2	Hydrostatic - Package	1
16A	1721536		Hydrostatic - Package (Tapered control shaft)	1
17	1719865	ET-8487	"O" Ring (Transmission Housing)	1
18	1719866	ET-8369	"O" Ring (Connecting Tube)	7
19	1719867	ET-93670	Tube - Connecting	1
20	1719868	ET-93671	Bushing (Parking Pawl)	1
21	1719869	ET-94897	Sealing Washer - 1" I.D. (Parking Pawl)	1
22	1719870	ET-82052	Quad - Ring (Parking Pawl)	1
23	1720312	ET-8278	"O" Ring (Parking Pawl)	1
24	1719871	ET-62087	Parking Pawl	1
25	1719872	ER-94043-1 -1/4	Cap Screw 3/8-16 UNC x 1-1/4 Spec	8
26	1719873	ET-22445	Axle Housing Sub-Assembly	1
27	1719874	ET-82051	Gasket (Housing)	1
28	1720313	ET-94857	Needle Bearing 1-3/8 I.D.	2
29	1719875	ET-94430	Spacer	1
30	1719876	ER-90101-3/4	Dowel 5/16 x 3/4	2
31	1720314	ET-93660	Needle Bearing (Closed End)	1
32	1720315	ET-94275	Needle Bearing	2
33	1719877	ET-94276	Oil Seal (Axles)	2
34	1106944	ET-94760-3-1/2	Capscrew 3/18-16 UNC x 3-1/2 (Use 1106944)	6
35	1719978	ET-60022-2	Axle (Left Hand)	1
36	1719879	ET-50115	Cover (Left Hand)	1
37	1719880	ET-40486	Ring Gear	1
38	1719881	ET-94861-5	Shim .500	As Req'd
38	1720307	ET-94861-10	Shim .010	As Req'd
39	1719882	ET-40487	Side Gear (Differential)	2
40	1719883	ET-94858	Thrust Washer	2
41	1719884	ET-40473	Pinion Gear (Differential)	2
42	1720317	ET-94859	Retaining Ring	2
43	1719885	ET-60021	Shaft	1
44	1719886	ET-50116	Cover (Right Hand)	1
45	1719887	ET-60022-1	Axle (Right Hand)	1
46	1720318	ET-94414	Needle Bearing	1
47	1720319	ET-94417	Bowed "E" Ring	1
48	1719888	ET-40431	Bull Gear	1
49	1719889	ET-94416	Spacer	1
50	1719890	ET-42063	Intermediate Gear	1
51	1719891	ET-22560	Transmission Housing Sub-Assembly	1
52	1719892	ET-93762	Coupling	1
53	1719893	ER-9458	Snap Ring (Brake Shaft)	1
54	1719894	ET-8576	Oil Seal (Brake)	1
55	1719895	ET-93766	Flange Bearing Adapter	1
56	1720320	ER-90797	Ball Bearing	1
57	1719896	ER-91231	Snap Ring (Bearing)	1
58	1719897	ET-62103	Brake Shaft	1
59	1106874	ET-93708-3/4	Capscrew 5/16-18 UNC x 3/4 (Use 1106874)	7
60	1719898	ET-82057	Gasket (Brake Flange)	1
61	1719899	ET-93758	Sealing Washer (Brake Bolts)	4
62	1720288	ETS-22631	Gasket Kit (Use when replacing #16) (Includes #3, 11, 13, 17, 18, 60, 61)	1
63	1720289	ETS-22632	Gasket Kit (For entire assembly) (Includes #14A, 21, 22, 23, 27, 62)	1

NOTE: When replacing hydrostatic package, if the present package has a straight control shaft order Part #171-9864; the new control arm for a tapered shaft will automatically be included with the package. If the present hydrostatic package has a tapered control shaft, order Part #172-1536.

## Don and Pete Duff's notes

First let me say that in my opinion the Eaton-12 hydro & rear combination had the best features in a garden tractor ever made and if you ever used one you would know why. One was the P-N-D feature (Park – Neutral – Drive). In P or N it allowed you to start the engine with no back pressure a great help in cold weather, the park is like your car/pickup park, you can hold the tractor on a steep hill with the hydro pedal and put in park. This is easier then trying to set a parking break.

### **To take your Eaton 12 hydro apart,**

Are you taking it apart for checking for wear or it does not move? If it does not move but the hydraulic lift works, there is one thing you can check without removing the hydro, that is the shuttle valve. You have to remove seat & pan assembly then the P-N-D valve and the top cover from the rear itself.



You will see three screw plugs, under the one on the left hand side is the shuttle valve, if you can see small rounded piece your shuttle valve is good, if you see a hole about 5/16" your shuttle valve is broken and you must find the broken parts, to remove the old shuttle valve insert a 3/8-16 tap in the 5/16" hole, with threads in the old valve you can use a standard 3/8" bolt as a puller to remove without hurting the bore of the hole so a new shuttle valve can be installed.



Under the right side cap is a check ball & spring for the P-N-D oil bypass; this is for easy starting and rolling the tractor. The ball is 0.437 in diameter and the tapered spring is about 7/8" long. If the spring is broken tractor will not have drive power.



Check ball & spring for the P-N-D oil bypass

To remove the finned alum front cover on front of the hydro, you need to remove two 3/8" bolts & one 1/2" bolt from the rear of the centre section.

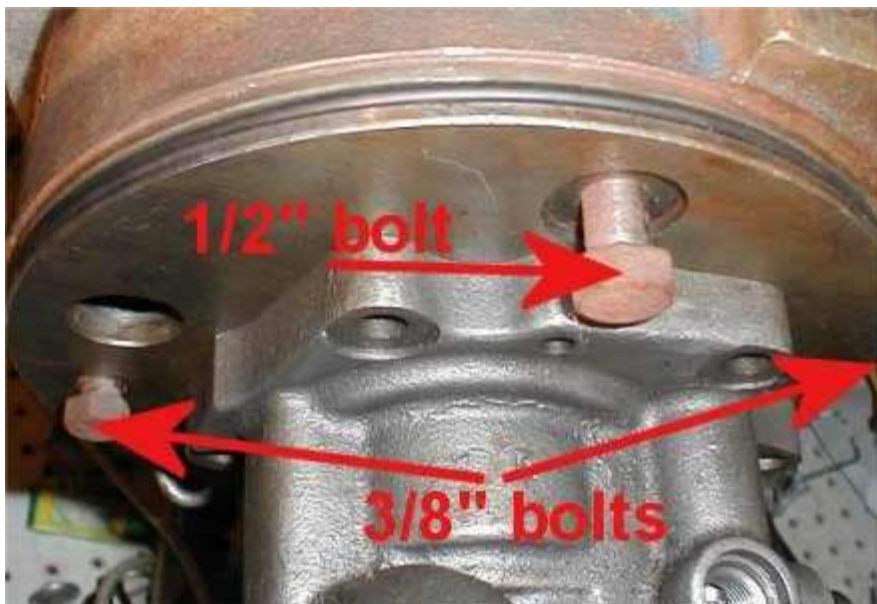

This allows the finned cover to be removed so you can check your slippers (7), pistons (7) & cam ring for wear or to replace them.



Radial pump with new (used) and worn slippers



Worn and new (used) slippers



Worn cam ring



Can ring machined and sanded

Also on the rotor is a roller thrust bearing consisting of a thin race 0.032 thick, a roller bearing 0.075 wide and a thicker race 0.093 thick (thin race towards the rotor).



To check or change the charge pump you must remove the drive motor casting from the centre section. There are five 3/8" bolts holding this together. Remove the large "O"-ring from the finned aluminium cover and put back on with the slippers, pistons & cam ring removed with two of the 3/8" bolts to hold it. Now you can remove the five 3/8" bolts holding the drive motor & charge pump wear plate from the centre section.



There are two other bolts on the other side.

With the drive motor removed you can check the charge pump ring & rollers for wear or replacement and also check the wear plate for wear or groves. Under the charge pump wear plate is a tapered spring & plunger. This spring is about 1 3/16" long. The charge pump is made up of a ring with six rollers 0.250 in diameter X 0.562 long, a drive key (round 3/16" in diameter X 3/8" long) and an outer ring in the gear motor housing with a bore 2.940 - 2.450 inside diameter.

You can also check the pintle shaft for wear or groves, (pintle size 1.437 in diameter) there is a snap ring holding the pintle shaft to the gear motor housing. Remove this snap ring and pull out straight. There is a dowel pin in there for line up purposes and two "O"-rings. With the drive motor section removed, turn the hydro so you remove the front finned cover. Now you can remove the rotor. The rotor comes out the front of the hydro and has seven holes for the pistons. It also has a bushing inside the centre of it (that rides on the pintle shaft). That bushing should be 1.4375 to 1.438 in size. If much larger in diameter or a groove wore between the seven holes, the bushing should be replaced or the oil will bypass making the tractor lose drive power. The front of the rotor is also the input shaft that should be 0.875 in diameter with a good woodruff key.

To check the drive motor gears, (the gears & housing should be checked if you had a broken shuttle valve) bearings or the drive key (round key) remove the eight (8) 3/8" bolts from the side of the gear motor. Take out the gear & shaft for repair or replacement.





The short shaft is on top for brake rotor coupling while the long splined on the bottom for drive gear both shafts come out the right side.



## Charge Pump

The charge pump is a secondary pump used for auxiliary accessories as the hydraulic cylinder.



Six rollers pins 1/4 X 9/16

