

Owner Operation and Maintenance Manual

SNOW-CASTER
42 INCH
MODEL 18044-01

TO THE OWNER

This is an operational and general maintenance manual only and does not cover major repair. All major repair work must be performed by an authorized BOLENS DEALER or the factory warranty is void. Bolens equipment is carefully engineered to give good performance if properly operated and maintained. Keep your equipment clean and lubricate it as prescribed in this manual. Periodically inspect your unit and perform any upkeep maintenance necessary.

Your dealer is obligated by the factory to completely assemble and service new equipment prior to first delivery, and thoroughly explain and demonstrate its operation. He will repair or replace any parts which fall due to defective material and/or workmanship during the warranty period, and also provide future repair service and supply genuine factory repair parts.

IN EVENT OF ANY PROBLEM OR PARTS REQUIRED ALWAYS CONTACT YOUR DEALER. DO NOT RETURN PARTS TO THE FACTORY. WE REQUIRE PRIOR FACTORY APPROVAL ON RETURNS, AND APPROVALS ARE ISSUED ONLY TO BOLENS DEALERS OR DISTRIBUTORS.

GENERAL SAFETY PRECAUTIONS

Preventing accidents is the responsibility of every equipment operator. The following general safety precautions must be fully understood and followed by every operator of this equipment. Review them frequently and NEVER TAKE CHANCES. BE CAREFUL BEFORE, DURING AND RIGHT AFTER USE OF ANY POWERED EQUIPMENT. ACCIDENTS CAN BE PREVENTED.

(1) Before starting the engine, disengage the P.T.O. and place shift lever in neutral or park position, to prevent unit from being started in gear.

(2) Do not allow children to operate vehicle at any time. The average child is not mentally capable of coping with the intricacies of operating a power tool.

(3) Do not allow adults to operate vehicle without proper instructions including all safety instructions. In doing so, you will be sure they know how to operate unit properly and also are aware of all the safety precautions.



(4) Study your manual. Know your unit before operating it. Take time to operate unit in the safest manner.

(5) Never operate tractor with snow caster or any other attachment having moving parts when any child or person is in travel path or discharge area. Children must not be allowed in or near working areas when equipment is being used. Items or objects such as wire, stones, small toys and etc. can be ejected at high velocity out of the discharge chute.

(6) Do not carry passengers. The passengers could fall off vehicle receiving injuries.

(7) Should the chute become plugged due to overload, disengage the rotor, shut off the engine and dislodge the packed snow WITH A STICK.

(8) NEVER ATTEMPT TO CLEAR ROTOR OR CHUTE WITH HANDS OR FEET, OR WHILE ROTOR IS TURNING, AS INJURY TO THE HANDS OR FEET COULD RESULT.

(9) Disengage rotor, shut off engine if anyone approaches running unit. This would help eliminate accidental injury to other persons by running unit.



BOLENS

PORT WASHINGTON WISCONSIN, U.S.A.

(10) The operator should always bear in mind that objects can be thrown by this machine. Care should be exercised to provide proper chute direction and deflector cap adjustment so to avoid throwing snow and possible foreign material at people, autos, windowns, pets, etc.

(11) Engine must be stopped, and P.T.O. disengaged when cleaning, servicing, adjusting, repairing, or installing attachments on tractor. This is necessary to avoid possible injury from moving parts.

(12) Adjust height to clear gravel or crushed rock surface, to avoid throwing stones and gravel accidentally.

(13) Keep tractor and attachments free of excess grease and oil. The unit will operate cooler, be easier to maintain, and safer to operate.

(14) Do not mount or leave vehicle while it is in motion or in actual operation, nor leave vehicle unattended while engine is running. Injury to the operator or a tractor run away could occur.

(15) Never wear loose clothing when operating unit. Loose clothing can get caught in moving parts and cause severe injuries.

(16) Study all attachment manuals thoroughly before using attachments with tractor, in so doing you will then be aware of both the tractor's and attachment's capabilities when used as a unit, also the safest manner in which to operate them.

(17) Always look back to be certain no one is in the way before using reverse. This will avoid the possibility of running over any children, persons or pets who might be in the area in back of the vehicle.

MODEL NUMBER

To ensure prompt service when repairs or adjustments are required, your Bolens Dealer must have the following information:

For your own personal reference, fill in the space provided below.

Model Number of Unit

Your Bolens Dealer has available a master Parts List for your unit. He can identify any parts you may require and furnish genuine factory replacements.

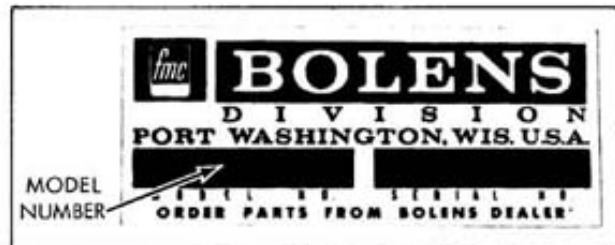

FIGURE 1

ASSEMBLY

This Snow Caster attachment is shipped complete with all parts required to mount it to your Husky tractor. To facilitate packaging requirements, the hitch, chute control crank and shoes have been shipped loose and must be assembled as follows:

(1) After removing the snow caster from its carton, mount the hitch as shown in Fig. 2 using four 3/8-16 x 2-1/4" hex head cap screws, lock washers and hex nuts.

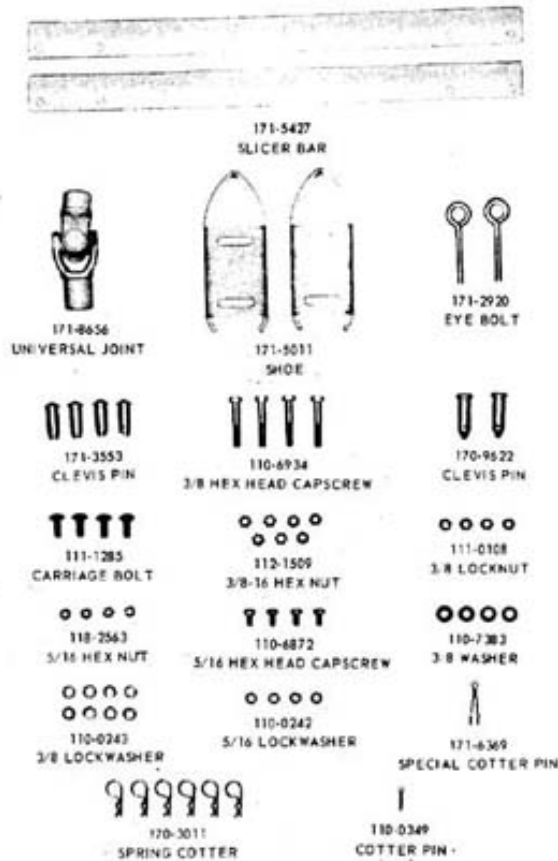

FIGURE 2. LOOSE PARTS

(2) Mount the shoes to the bottom outside of rotor housing as shown in Fig. 4 using the four 5/16-18 x 3/4 hex head cap screws, flat washers, lock washers, and lock nuts provided. The mounting holes are slotted so the unit can be raised or lowered, depending on the smoothness of the surface to be cleared.

(3) The chute control rod should be mounted after the snow caster has been mounted to the tractor.

MOUNTING

(1) Slide universal joint on to the universal drive, and with tractor on a level surface, slide snow caster hitch under front of tractor, guiding the universal on to the front splined end of tractor power take off shaft. Secure with special cotter pin provided.

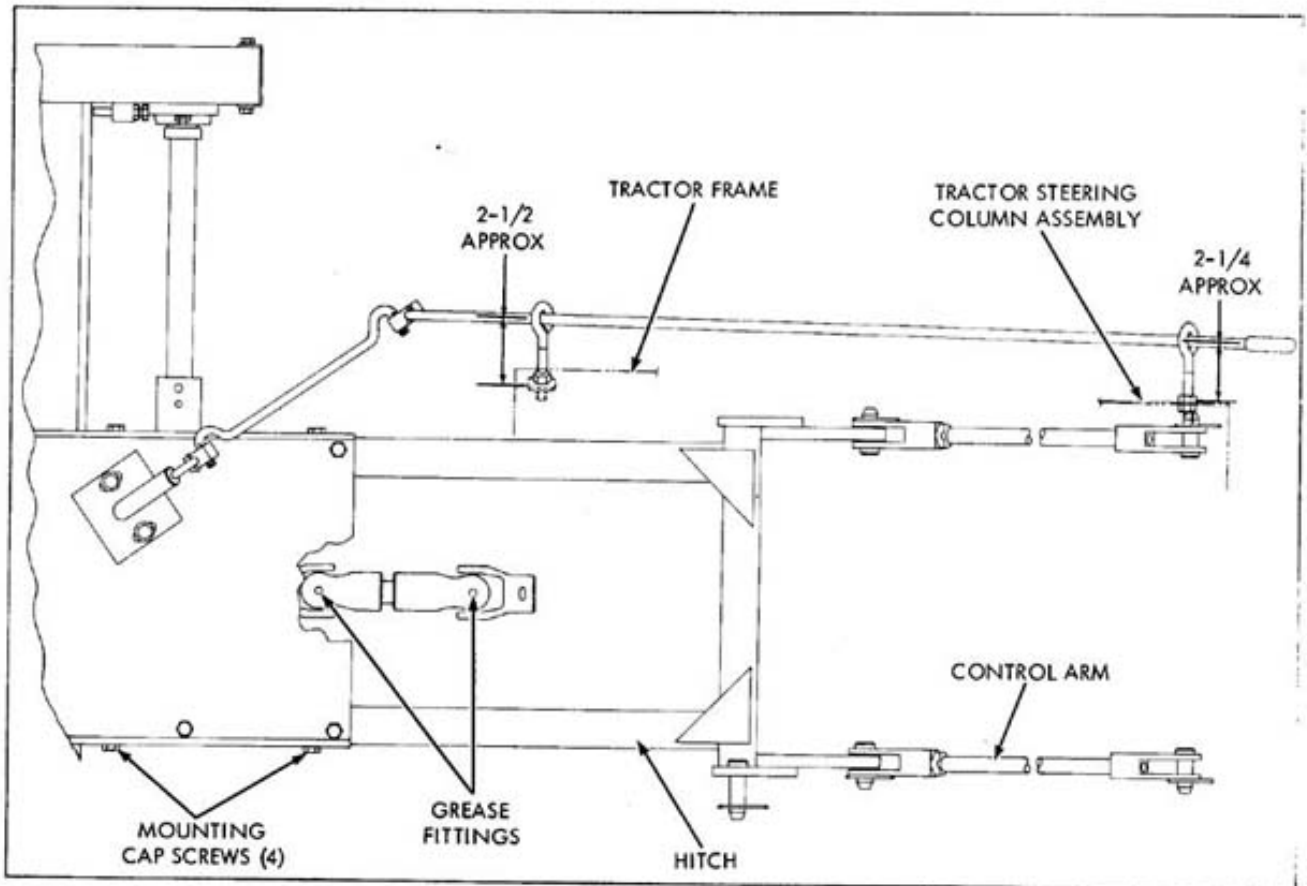

FIGURE 3

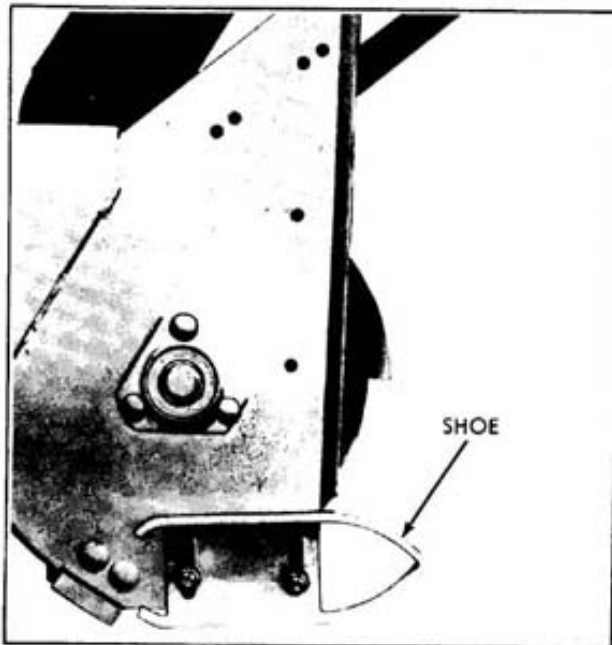

FIGURE 4

(2) Next secure the two vertical hitch arms to the tractor implement hitch-arms with the two 2-1/8 x 5/8" clevis pins and spring cotter provided, as shown in Fig. 5.

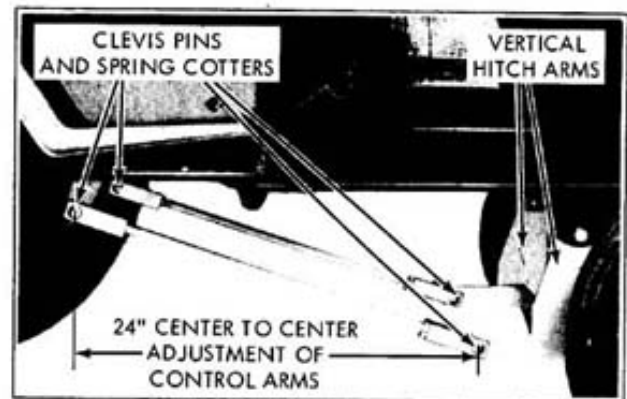

FIGURE 5

(3) With tractor selector lever in the PARK position, start tractor and pull implement lift lever down into the float position.

(4) Shut off engine and attach the two control arms to the tractor lift arms with clevis pins and spring cotters. Adjust right hand control rod so that there is 24" between center lines of clevis mounting holes and secure to the right hand horizontal hitch arm with clevis pin and spring cotter as shown in Fig. 5. Adjust left hand control rod as required and secure to left hand hitch arm with remaining clevis pin and spring cotter.

(5) Start engine and raise unit to the maximum height. Check for front frame casting vs. universal

joint clearance. (NOTE: This hook-up will allow for approximately 10" of lift above horizontal and approximately 5" below horizontal.)

IMPORTANT

ALWAYS REMOVE UNIVERSAL JOINT FROM POWER TAKE OFF SHAFT IF SNOW CASTER IS REMOVED FROM TRACTOR. IF THE JOINT IS NOT REMOVED AND THE POWER TAKE OFF IS ENGAGED, DAMAGE WILL RESULT FROM WHIPPING ACTION OF THE FREE JOINT.

CRANK HANDLE ASSEMBLY

To mount crank handle assembly, first mount the two eye bolts on right side of tractor frame (lower bolt) and metal housing (upper bolt) as shown in Fig. 6. Next, slip the crank handle through the eye bolts from lower eye bolt up. Handle end first, then position the eye bolts so that the crank handle moves freely and lock the eye bolts in place. NOTE: See Fig. 3 for correct mounting of eye bolts. Then attach the crank handle assembly to the swivel blocks as shown in Fig. 6 and insert cotter keys.

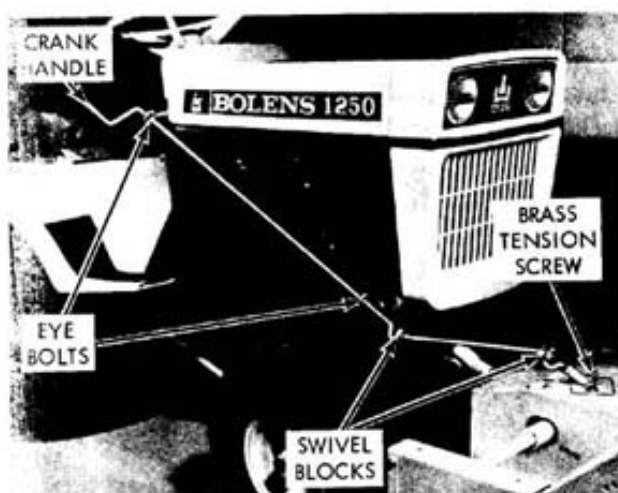

FIGURE 6

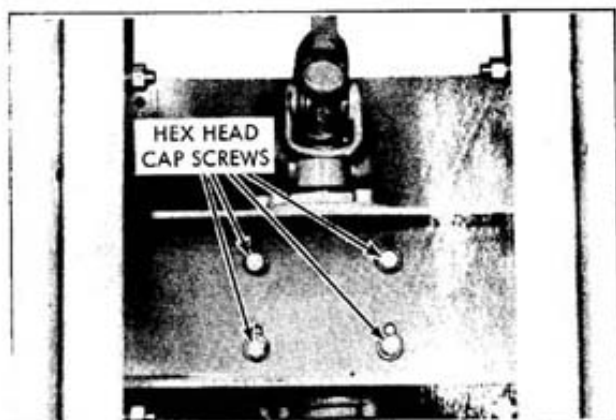

FIGURE 7

CHAIN TENSION

The chain is properly adjusted with just a slight amount of slack between the sprockets when assembled at the factory. A chain too loose is inclined to jump and too tight a chain will cause excessive wear of chain and sprockets.

To adjust chain tension, first loosen the four hex head cap screws located beneath the gear box assembly, as shown in Fig. 7. Next loosen the two carriage bolts which mount the self-aligning bearing to the rotor drive shaft, as shown in Fig. 8. Then loosen the hex nut and adjust the hex head cap screw to position sprocket to the desired chain tension.

IMPORTANT

BE SURE TO MOVE THE GEAR CASE AND THE SPROCKET AN EQUAL DISTANCE TO MAINTAIN PROPER ALIGNMENT OF THE CHAIN ON THE SPROCKET.

Tighten the two carriage bolts which mount the bearing and the four cap screws under the gear box.

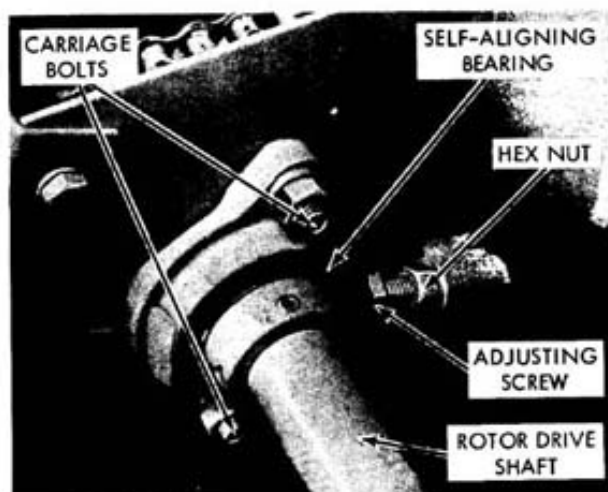

FIGURE 8

LUBRICATION

The Snow Caster has two grease fittings: one on each power driven universal joint. Lubricate working parts with light oil for smoother performance and to reduce wear. The gear case is filled at the factory to filler hole level with #90 SAE gear lubricant. Check oil level before using the Snow Caster and every 6 hours of operation thereafter. Add #90 SAE lubricant as necessary to maintain filler hole level.

OPERATION

There are three controls for operating the Snow Caster: the tractor power take off lever for engaging and disengaging the rotor; the tractor lift lever for raising and lowering the Snow Caster; and the

chute control crank for controlling the direction of discharge.

The brass tension screw shown in Fig. 6 is set to act as a drag on the shaft to prevent the duct assembly from turning in operation due to the force of the snow. As adjustment becomes necessary, tighten the screw until a dragging action is noticed when rotating the discharge chute. **CAUTION: DO NOT TIGHTEN SO AS TO CAUSE A BINDING OF THE CHUTE CONTROL CRANK.**

If, when the duct is turning, it binds on the housing assembly, adjust the two hex head cap screws (Fig. 9) which secure the closure plate to the housing.

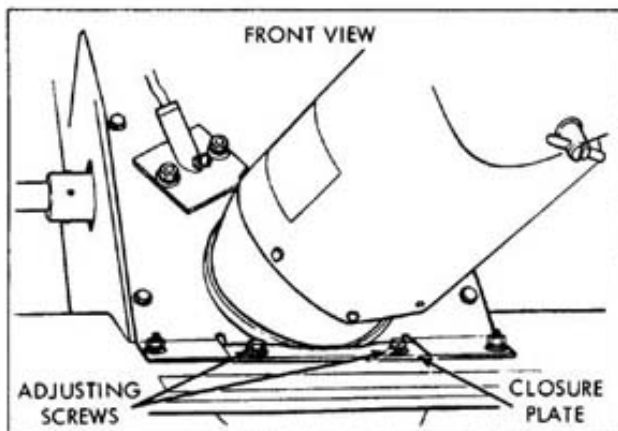

FIGURE 9

In deep snow, the initial or full width cut should be made by partially raising the Snow Caster and moving forward as far as possible. Then reverse the tractor, lower the Snow Caster and remove the remaining portion of snow. When using the Snow Caster in light snow or in cleaning scattered remains, operate the tractor at a higher ground speed to maintain a stream of snow coming out of the chute. Small amounts of snow in intermittent intervals may cause a build up of snow in the chute resulting in eventual chute clogging.

CAUTION:

- (1) Before starting the tractor, be sure the Snow Caster is disengaged.
- (2) Under normal conditions always operate tractor with engine at full throttle and at a low ground speed to assure maximum power and casting distance.
- (3) Do not overload the Snow Caster in deep snow, but rather reduce the width of cut to maintain full engine RPM to effect full casting distance.
- (4) Should the Snow Caster become overloaded, stop the forward motion until the unit has cleared and full engine RPM is evident.
- (5) Should the chute become plugged due to overload, disengage the rotor, shut off the engine and dislodge

the packed snow WITH A STICK. NEVER ATTEMPT TO CLEAR ROTOR OR CHUTE WITH HANDS OR FEET, OR WHILE ENGINE IS RUNNING.

DRIFT SLICER

A drift slicer is supplied which may be installed when operating in deep snow. It can be mounted on either upper inside wall of rotor housing with 5/16-18 x 3/4" cap screws supplied, as shown in Fig. 10.

EXTENSION KIT

The Extension Kit (Part No. 18043-01) is for use with tractors equipped with high flotation tires to cut a path wide enough to accommodate the wider tires. See Fig. 10. These extensions may be purchased from your Bolens Dealer.

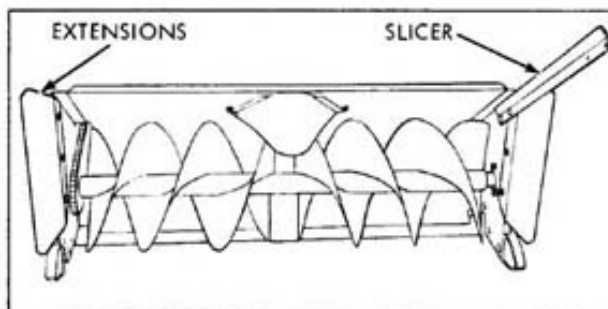

FIGURE 10

STORAGE

If the unit is stored in heated quarters, allow it to cool to outside temperature before operating. This will help to prevent snow from sticking to the rotor housing, and discharge chute. Before storing the unit or allowing it to stand idle in freezing weather, remove snow from rotor as heavy icing could result in damage when attempting to restart unit. When stored for a long period of time, coat exposed parts with a light film of grease to prevent rusting.

Bolens reserves the right to change specifications, add improvements or discontinue the manufacture of any of its equipment without notice or obligation to purchasers of its equipment when equipment was purchased prior to decision to make changes, add improvements or discontinue manufacture.

Bolens approval of use of attachments manufactured by other manufacturers is limited to assurance that such use will not void Bolens warranty on the Bolens equipment to which the outside manufactured attachments is adapted. The responsibility for the design, performance, durability, safety in operation, service repair availability, and warranty obligation remain with the outside manufacturer. Bolens specifically excludes from its warranty obligation all such outside manufactured attachments.

Bolens warranty will be voided if unapproved attachments are adapted to use with Bolens equipment and are so used.

ILLUSTRATED PARTS LIST

BOLENS
42 INCH
SNO-CASTER
ATTACHMENT
MODEL 18044-01

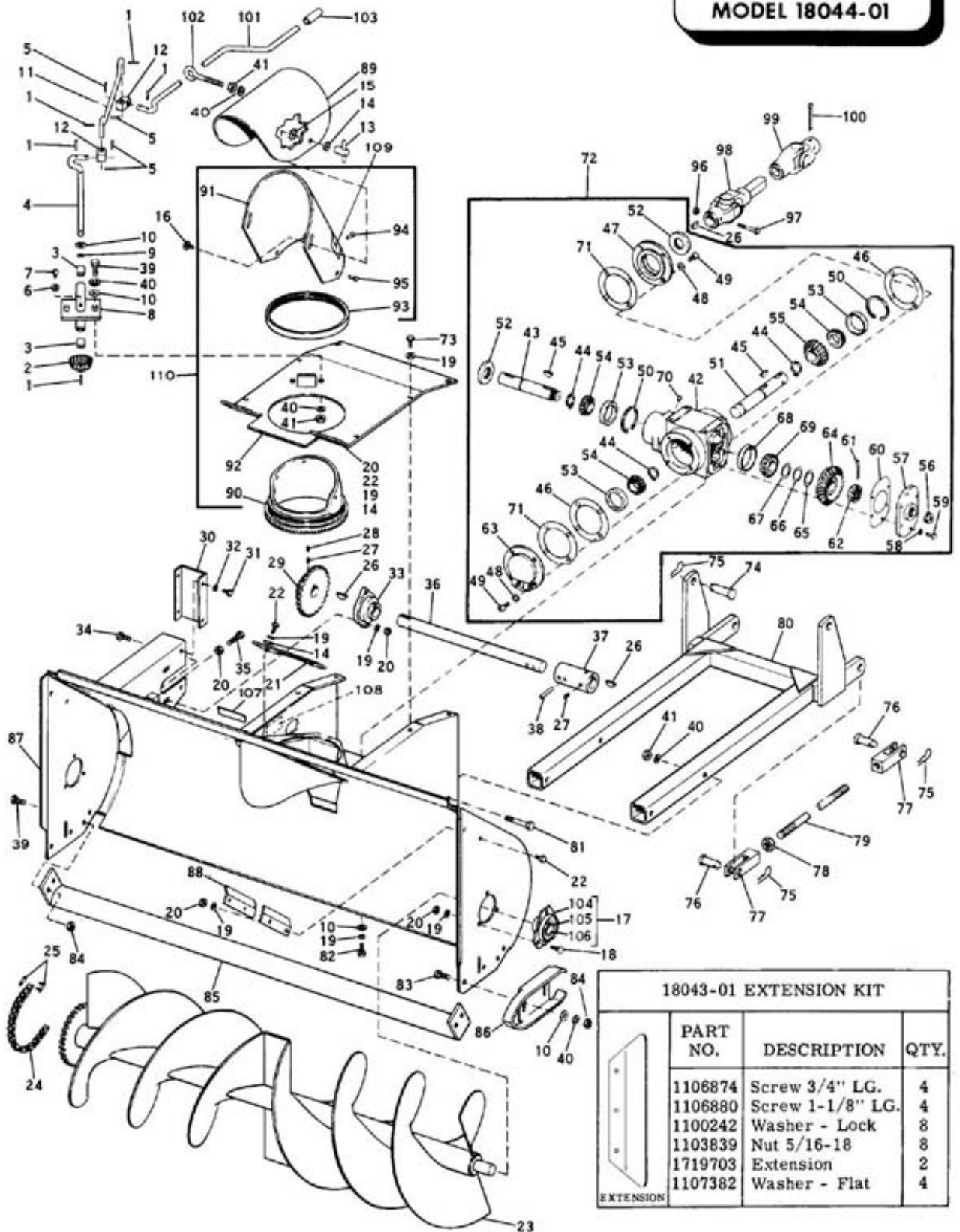

LITHO IN U.S.A.

FORM NO. P-551942 7-69

42" SNO-CASTER ATTACHMENT MODEL 18044-01

Ref. No.	Part No.	Description	No. Req'd.
1	1703066	Drive Pin 1/8 x 3/4	6
2	1714367	Chute Control Pinion	1
3	1185395	Sleeve Bearing	2
4	1717017	Chute Control Shaft	1
5	1100349	Cotter Pin 1/8 x 3/4	4
6	1121507	Hex Nut 1/4 x 20	1
7	1102571	Mach. Screw 1/4-20 x 3/4	1
8	1719333	Chute Control Assembly	1
9	1705119	Bowed Washer	As Req'd.
10	1107383	Flat Washer 3/8	11
11	1719344	Chute Control Rod	1
12	1714782	Swivel Block	2
13	1714373	Wing Nut	2
14	1107382	Flat Washer 5/16	6
15	1185569	Shakeproof Washer	2
16	1185518	Square Bolt 1/4-20 x 5/8	2
17	1717076	Self-Aligning Br. Assy (Inc. Ref. #104-105-106)	2
18	1111265	Carriage Bolt 5/16-18 x 3/4	6
19	1100242	Lockwasher 5/16	26
20	1182563	Hex Nut 5/16-18	15
21	1718714	Closure Plate	1
22	1106872	Capscrew 5/16-18 x 5/8	8
23	1721278	Rotor Assembly	1
24	1719343	Drive Chain	1
25	1185026	Connector Link	1
26	1100276	Woodruff Key 1/4 x 7/8	3
27	1182554	Set Screw 5/16-18 x 5/16	4
28	1185259	Set Screw 5/16-18 x 1/4	2
29	1718757	Sprocket - 26T	1
30	1718771	End Cover	1
31	1106830	Capscrew 1/4-20 x 1/2	4
32	1100241	Lockwasher 1/4	4
33	1718764	Self-Aligning Bearing	1
34	1111266	Carriage Bolt 5/16-18 x 1	2
35	1185742	Capscrew 5/16-18 x 2	1
36	1718715	Rotor Drive Shaft	1
37	1718718	Coupling	1
38	1187614	Drive Pin 1/4 x 1-3/4	1
39	1111284	Bolt, Carriage 3/8-16 x 3/4	2
40	1100243	Lockwasher 3/8	16
41	1121509	Hex Nut 3/8 x 16	9
42	1719710	Gear Case (Incl. 65, 66, 67, 68, 69)	1
43	1718721	Shaft - Output	1
44	1185689	Retaining Ring	3
45	1709611	Woodruff Key 1/4 x 7/8	2
46	1717456	Gear Box Gasket	As Req'd.
47	1717454	Bearing Retainer	1
48	1100242	Lockwasher 5/16	8
49	1185686	Capscrew 5/16-18 x 3/4	8
50	1118735	Retaining Ring	2
51	1718720	Shaft - Input	1
52	1185687	Oil Seal	2
53	1185660	Bearing Cup	3
54	1185661	Bearing Cone	3
55	1717457	Bevel Pinion - 18T	1

Ref. No.	Part No.	Description	No. Req'd.
56	1100937	Pipe Plug 3/4 N.P.T.	1
57	1717448	Cover	1
58	1100241	Lockwasher 1/4	6
59	1185684	Capscrew 1/4-20 x 5/8	6
60	1717449	Gasket	1
61	1100352	Cotter Pin 1/8 x 1-1/2	1
62	1185662	Slotted Nut 7/8 x 14	1
63	1718620	Bearing Retainer	1
64	1717459	Bevel Gear - 29T	1
65	1800750	Shim - .003	1
66	1800751	Shim - .005	1
67	1800338	Shim - .015	1
68	1185118	Bearing Cup	1
69	1185688	Bearing Cone	1
70	182682	Breather	1
71	1719501	Gear Box Gasket	As Req'd.
72	1718740	Gear Case Assembly	1
73	1106870	Capscrew 5/16-18 x 1/2	6
74	1709622	Clevis Pin	2
75	1703011	Spring Cotter	6
76	1713553	Clevis Pin	4
77	1714573	End Rod	4
78	1108891	Jam Nut 5/8 x 11	2
79	1719096	Push Rod	2
80	1718713	Hitch Assembly	1
81	1106934	Capscrew 3/8-16 x 2-1/4	4
82	1106874	Capscrew 5/16-18 x 3/4	4
83	1111285	Carriage Bolt 3/8-16 x 1	4
84	1110108	Self-Locking Nut 3/8 x 16	8
85	1718734	Scraper Assembly	1
86	1715011	Shoe	2
87	1721277	Rotor Housing Assembly	1
88	1715427	Drift Slicer	2
89	1718723	Deflector Cap	1
90	1718730	Swivel Duct	1
91	1718722	Outlet Duct	1
92	1718724	Gear Cover	1
93	1719394	Seal Ring	1
94	1104045	Button Rivet 3/16 x 1/2	2
95	1100617	Button Rivet 3/16 x 3/4	2
96	1110106	Lock Nut 1/4 x 20	1
97	1106849	Capscrew 1/4-20 x 1-3/4	1
*98	1718618	Universal Joint Assembly	1
*99	1718656	Universal Joint	1
100	1716369	Cotter Pin	1
101	1719345	Crank Handle Rod	1
102	1712920	Eye - Bolt	2
103	1715685	Grip	1
104	1185787	Flange	4
105	1185788	Collar	2
106	1185587	Bearing Only	2
107	1716053	Decal (Bolens)	1
108	1719347	Decal (Shear Pin)	1
109	1715670	Decal (Caution)	1
110	1718739	Duct Assy (Inc Ref #90-91-92-93-94-95)	1

*1714207 Repair Kit for Joint Marked 6N

*1714208 Repair Kit for Joint Marked Neapco



PORT WASHINGTON, WISCONSIN, U.S.A.

LITHO IN U.S.A.

FORM NO. P-551942 7-69

MyTractorForum.com